



Read and fully understand the instructions before operating the Portek Post Driver

Post Driver



portek.co.uk

Operators Handbook

Before you start

READ AND UNDERSTAND THIS MANUAL FULLY BEFORE OPERATING THE POST DRIVER



The Post Driver is a high-speed, driving power tool, special safety precautions must be observed to reduce risk of personal injury. Read this manual carefully. Be familiar with the controls and the proper use of the unit. Know how to shut it off quickly.

This graphic accompanied by the words **WARNING** and **DANGER** highlights an act or a condition which can lead to **SERIOUS INJURY**



ALWAYS WEAR EYE AND EAR PROTECTION.

Always **TURN OFF ENGINE** and make sure the Post Driver has stopped before cleaning, removing or adjusting.

DISCONNECT spark plug lead before cleaning or essential maintenance to the Post Driver.

WARNING! Never modify the Post Driver in any way.

Improper use of any Post Driver can cause **SERIOUS OR FATAL PERSONAL INJURY**.

The engine exhaust from this product contains chemicals to cause cancer, birth defects, or other reproductive harm.

Specifications, descriptions and illustrative material in this manual are as accurate as known at the time of publication, but are subject to change without notice. Illustrations may include optional equipment and accessories, and may not include all standard equipment.

Proper safety precautions must be observed. Like all equipment this unit must be handled carefully **DO NOT EXPOSE YOURSELF TO DANGER**. Follow these general rules. Do not permit others to use the Post Driver unless they are thoroughly responsible and have read, and understand the machine manual and are trained in its operation.

Always wear hard hat, ear defenders and safety goggles for protection. Dress properly, do not wear loose clothing or jewellery that could become caught in moving parts of the unit. Safe, sturdy, steel toe cap non skid footwear should always be worn. Long hair should be tied back. Legs and feet be covered to protect from flying debris during operation.

ALWAYS WEAR SAFETY CLOTHING IN CONJUNCTION WITH HAND, EYE, HEARING AND FOOT PROTECTION TO HSE/EN SPECIFICATIONS - SEE PAGE 6



Important safety information

Before use, inspect the entire machine for loose parts (nuts, bolts, screws, etc.) and any damage. Repair or replace as necessary before using this machine. Serious injury to the operator or bystanders could result as well as damage to the machine.

Keep the handles free from oil and fuel.

Do not smoke while mixing fuel or filling tank.



Do not mix fuel in an enclosed room or near open flames. Assure adequate ventilation.

Always mix and store the fuel in a properly marked container that is approved by local codes and ordinances for such usage.

Never remove the fuel tank cap while the engine is running.

Before transport, always empty the fuel tank to avoid leakage.



Never start or run the engine inside a closed room or building. When being used in "closed areas" such as tunnels or trenches, make sure the area is well ventilated. Fumes from the exhaust contain dangerous carbon monoxide.



Never attempt to make engine adjustments while the unit is running. Always make engine adjustments with the unit resting on a flat, clear surface. **REMOVE SPARK PLUG LEAD TO PREVENT ACCIDENTAL STARTING**

Do not use the unit if it is damaged or poorly adjusted.

Keep children away. Onlookers should be kept at a safe distance from the work area, at least 15 metres/50 feet.

Never leave the machine unattended.



Do not use this unit for any job other than those for which it is intended as described in this manual.



While operating the machine do not overreach. Keep proper footing and balance at all times. Do not run the unit while standing on a ladder or on any other unstable footing location. Do not operate one-handed. The operator should be stood in front of the 'Air Filter' and operate the machine.

While lifting the machine, do not pull on the 'Throttle Switch', and carry out idle-speed operation of the machine.



Do not use the unit when you are tired or under the influence of medication, drugs or alcohol.

Important safety information



FOLLOW INSTRUCTIONS FOR CHANGING ACCESSORIES.

Do not store in a closed area where fuel vapours can reach an open flame from hot water heaters, furnaces etc. Store in a locked, well ventilated area only.

Use only PORTEK equipment parts when servicing the unit, this will ensure safe and proper performance of your product. These parts are available from your dealer. The use of any other accessories or attachments may cause a potential hazard to the user, damage to the machine and void this warranty.

When refuelling, be sure to stop the engine. **NEVER** refuel when the engine is running or has overheated. When gasoline spills, be sure to wipe it up completely and properly dispose of those materials before starting the engine.

Stay clear of other workers or bystanders by at least 15 metres/50 feet.

Whenever approaching an operator of the machine, carefully call his attention and confirm the operator stops the engine. Be careful not to startle or distract the operator which can cause an unsafe situation.

Pay attention to loosening and overheating of parts. If there is any abnormality of the machine, stop operation immediately and check that machine carefully. If necessary, have the machine serviced by an authorised dealer. Never continue to operate a machine which may be malfunctioning.

In start-up or during operation of the engine, never touch hot parts such as the muffler, the high voltage wire or the spark plug.

After the engine has stopped, the muffler is still hot. Never place the machine in any places where there are flammable materials (dry grass etc.) combustible gasses or combustible liquids.

AFTER USE

Clean the machine completely, especially the fuel tank, its surroundings and the air cleaner.

Pay special attention to operation in the rain or just after the rain as the ground may be slippery.

If you slip or fall to the ground, release the throttle lever immediately.

Be careful not to drop the machine or hit it against obstacles.

Before proceeding to adjust or repair the machine, be sure to stop the engine and detach the spark plug cap from the spark plug.

When the machine is placed in storage for a long time, drain fuel from the fuel tank and carburettor, clean the parts, move the machine to a safe place and confirm that the engine is cooled down.

Make periodic inspections to assure safe and efficient operation. For a thorough inspection of your machine, please contact a dealer.

Keep the machine away from fire or sparks.

CONTENTS

Important Safety Instructions	2 - 6
--------------------------------------	--------------

Specifications	7
-----------------------	----------

Setting Up	8
-------------------	----------

Operation	9
------------------	----------

Maintenance	11
--------------------	-----------

Troubleshooting & Spare Parts	15
--	-----------

Exploded Drawings	16
--------------------------	-----------

Certificate of Conformity	20
----------------------------------	-----------

Safety Equipment Requirements

Essential Equipment for Your Protection

The Portek Post Driver complies with all current safety standards. For your safety You must wear full protection as specified below.



Head, eye and hearing protection

Eye protection to EN166 – B

Hearing protection to EN 352-1: 2002

Face protection visor recommended



Hand protection

Gloves to EN 12477:2001



Foot protection

Boots to EN 20345:2011



Leg protection

Sturdy full length trousers - ideally to EN381 standard

Max power and speed:	1500W / 9,000rpm
Max torque and speed:	2.5N.m / 5,000rpm
Impact frequency:	700 ~ 1,350rpm
Impact energy:	20 ~ 55J
Noise level:	LpA: 104dB / LwA: 115dB
Vibration level:	13.891m/s ² / K=1.5m/s ²
Engine:	Single cylinder, air-cooled, 2 stroke petrol
Cylinder diameter × stroke:	44mm × 34mm
Capacity:	52cc
Max power output:	<1.42kW
Carburettor:	MZA 102H
Ignition:	Non-contact electronic ignition
Spark plug type:	L8RTC
Starting method:	Recoil type 'pull' starter
Fuel mixture:	25:1 - petrol:oil mixture
Fuel tank capacity:	1.3l
Fuel consumption rate:	≤0.60l/h
Weight of complete unit:	21kg
Length × width × height:	805mm × 305mm × 270mm

Post Driver box contents

Post Driver with main 4" capacity post holder fitted.

Reducing adaptor for using plastic post holders.

x3 plastic piling sizing rings: 20-49mm, 50-69mm and 70-100mm.

Lubricating grease (60g).

Instruction booklet.

Tool kit - comprising of: spark plug, spark plug handle, 4mm inner hexagon spanner, 5mm inner hexagon spanner, inner hexagon spanner 6mm, T-shaped inner hexagon spanner, straight screw-driver and 8-10mm open spanner.

Setting up

Post Holders and Sizing Rings

The pre-fitted post holder (part no. 075/02) on the machine can be used without further attachments for 4" diameter posts.

For smaller posts the reducing adaptor is screwed onto the end of the post holder, followed by a plastic sizing ring screwed on to the adaptor. You should choose the ring with the closest diameter to the post being driven.

The rings can easily be changed by screwing them off/on at the threaded end of the adaptor.

Important!

Care should always be taken to avoid damage to the threads of the post holder adaptor and sizing rings.

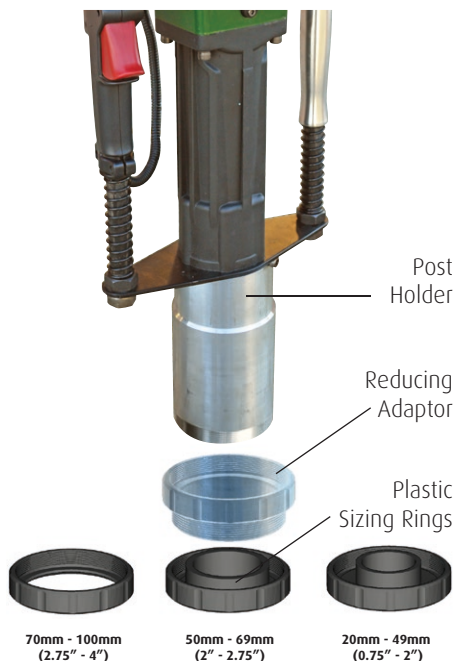

Optional Square Post Holder

An additional post holder (part no. 075/01) can be purchased which can be fitted to the machine as an alternative to the standard post holder. This can be used for square and rectangular posts of 4" square, 4x3" and 3" square sizes.



Changing the Post Holder

Using an allen key undo the 4 retaining bolts securing the 'Post Holder' to the machine, firmly slide the old holder off and push the new holder onto the end. Secure the new holder in place with the 4 retaining bolts and tighten firmly to make sure they do not loosen while the machine is in use.



Preparing the Fuel

Always refuel the Post Driver in a well ventilated area. Use the mixing container supplied to mix the petrol and 2 stroke oil (see specifications) in the ratio of 25:1. Fill the fuel tank of the Post Driver (do not overfill). The fuel level should not exceed the neck of 'Fuel Tank Filling Port'.

If you spill fuel during refill, clean up and then wait until the fuel has evaporated completely before restarting the machine. After refuelling, tighten and check the lid of Fuel tank before operation.

Recommended mixing ratios:

Operating Hours	Petrol:Engine Oil
Operation within 20 hours	20:1
Operation of over 20 hours	25:1

Starting

Before starting the Post Driver, prime the engine with fuel by pressing the flexible plastic bulb several times to pump the fuel into the carburettor. If the engine is cool, close the choke, but make sure you open it after starting.

With the Post Driver upright. Hold the upper part of handle tightly with one hand while the other pulls the pulling handle of starter for over 50cm quickly. Do not let the pulling handle go back freely in repeated pulling but hold it tightly to avoid injury resulting from quick recoil.

Start the engine and then open the choke completely. After idle operation of 5 minutes, start normal work.

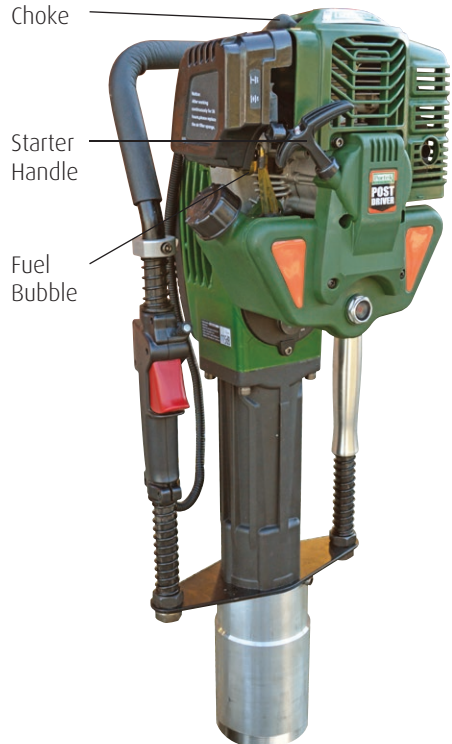

Stopping

To stop the Post Driver, release the 'Throttle Switch' and carry out idle running of the machine for 3-5 minutes. Then pull the 'Stop Switch' to the stop position.

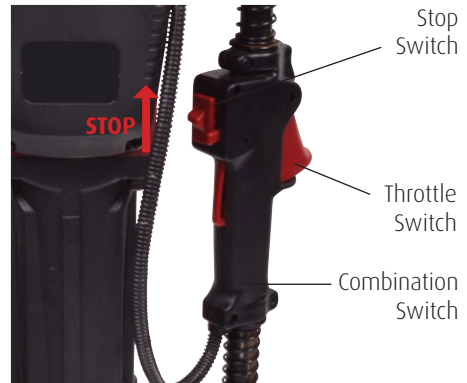

Once you have started the engine, allow the engine to carry out 'Idle Operation' of 5 minutes to give the Post Driver time to reach correct operating temperature.

When the engine is warm, press the 'Throttle Switch' to the appropriate operating position according to the required impact power.

The Post Driver should be run at low or medium-speed in the first 20 hours of operation and in order to extend the service life of the machine.

The Post Driver should not be run at high-speed during operation.

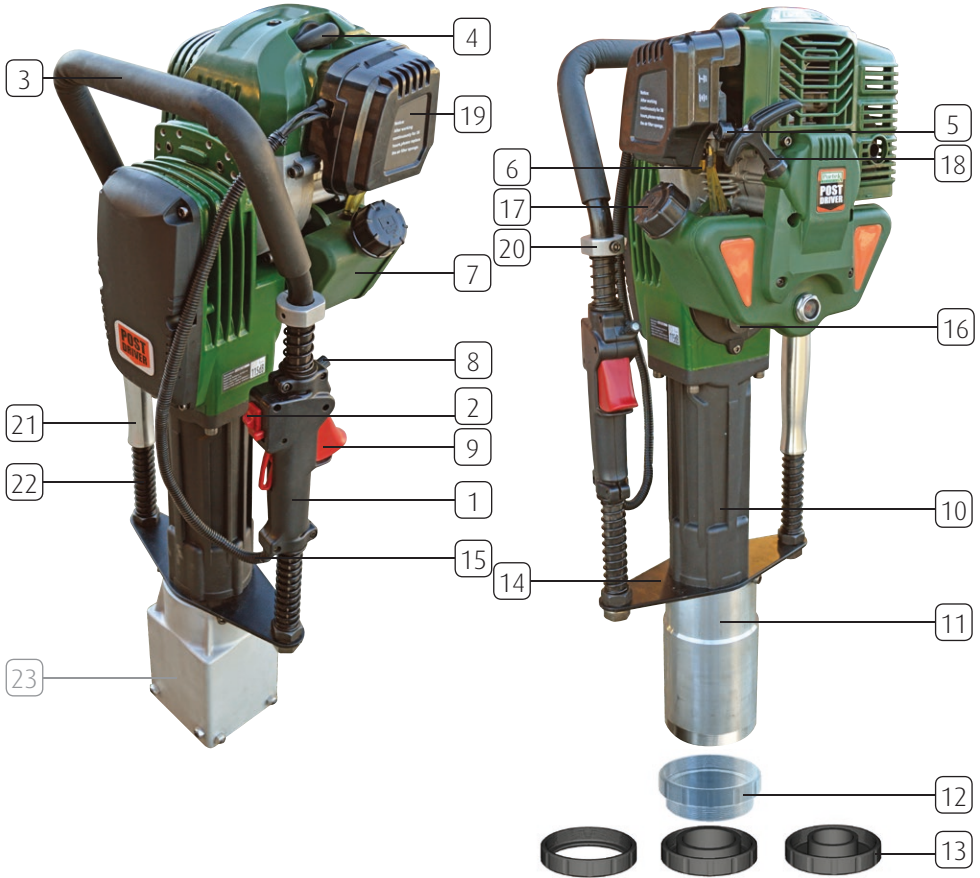

No. Description

- 1 Combination Switch
- 2 Stop Switch
- 3 Handle
- 4 Spark Plug
- 5 Choke Lever
- 6 Fuel Bubble
- 7 Fuel Tank
- 8 Throttle Cable Adjuster
- 9 Throttle Switch
- 10 Hammer Case
- 11 Standard Post Holder (Part No. 075/02)
- 12 Reducing Adaptor

No. Description

- 13 Plastic Sizing Rings
- 14 Support Plate
- 15 Throttle Cable
- 16 Lubricating Grease Filling Port
- 17 Fuel Tank Lid
- 18 Pull Cord
- 19 Air Filter
- 20 Positioning Sleeve
- 21 Grip
- 22 Damping Spring
- 23 Optional Post Holder (Part No. 075/01)

Air Filter

Check and clean the air filter on a regular basis. Soot deposits blocking the filter element will reduce the engine power and the service life of your Post Driver. If the filter has a high level of soot deposits, carefully remove it, and clean it with warm water and detergent. Leave to dry before refitting. The air filter should be replaced if damaged in any way.

Fuel Filter

If the fuel filter becomes blocked, the Post Driver engine power will become greatly reduced and you will find the impact energy will become weak. To check and clean the filter open the fuel tank lid and remove the fuel filter from tank, using a metal hook. While the fuel filter is removed, inspect the fuel tank at same time.



Carburettor

Over time oil residue may build up around the carburettor and the fuel tank, this is normal but you should take care that the greasy oil does not block the oil line to the engine and cause problems when starting. It is highly recommended that when the Post Driver is non-operational for long periods that the fuel is properly drained. To drain the carburettor of fuel, carefully pull out the oil inlet pipe and firmly press the rubber bubble of the carburettor repeatedly to discharge the fuel into a container. Continue to press the fuel bubble until the oil return pipe is empty. Replace the oil inlet pipe and clean off any spillage and oil residue from the Post Driver.

Spark Plug

To ensure normal operation of the engine, the spark plug gap must be properly maintained. Remove any sediment with a wire brush. The proper gap of the spark plug is 0.5 - 0.7mm.

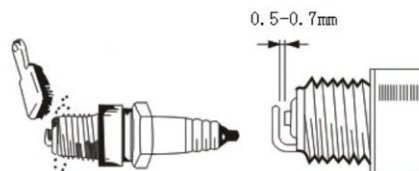

Muffler

Regularly remove any dirt build up with warm water and detergent from both the inlet and outlet of the muffler of the Post Driver.

The Cylinder Heat Sink

The Post Driver is air-cooled so regularly remove dust to ensure cylinder cooling. If dust accumulates on the cylinder heat sink, the cooling effect will be reduced, which may lead to failure of the cylinder.

Gearbox Lubrication

Open the gearbox cover and regularly inspect to make sure the gearbox drive gears are well lubricated.

Impact Cylinder Lubrication

The impact cylinder should be re-lubricated after every 50 hours of operation. Remove the screw "plug" with an allen key, before carefully adding 50g of lubricating grease.

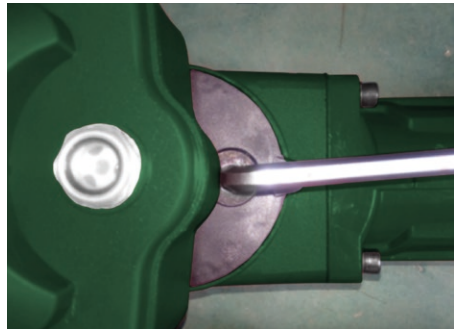
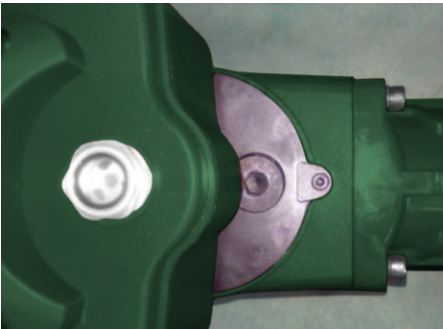

Maintenance

The Post Driver will provide reliable performance and service if maintained regularly.

The following intervals apply to normal operating conditions. If you are using the Post Driver in very dusty conditions or for long operating periods, adjust accordingly.

Please contact your Portek Dealer if in any doubt.

		before starting work	after finishing work or daily	after each refuelling stop	every week	every month	if problem or damaged	if required
Complete Post Driver machine	Check	X		X				
	Clean		X					
Controls	Check	X		X				
Air Filter	Clean				X			X
	Replace						X	
Fuel Filter	Check					X		
	Replace						X	
Fuel Tank & Cover	Clean		X	X				
	Check	X		X				
	Tighten							X
Gearbox/Cylinder	Check					X		
	Add Oil							X
Silencer	Check					X		
	Clean							X
Cooling Fan	Check					X		
	Clean							X
Spark Plug	Electrode gap (0.025" / 0.635mm)					X		
	Replace (every 100 operating hours)							X
All screws/nuts and fixings for tightness	Check	X		X				

Warranty

Warranty for your Post Driver is 12 months for domestic use and 3 months for any commercial or contractor use. Please retain your proof of purchase for any warranty claim.

Troubleshooting & spare parts



WARNING! Operating problems are often due to causes that the user can fix. Therefore check the product using this section to eliminate these simple issues. In most cases the problem can be solved quickly.



WARNING! Only perform the steps described below! All further inspection, maintenance and repair work must be performed by an authorised service centre or a similarly qualified specialist if you cannot solve the problem yourself! **IF IN DOUBT SEEK EXPERT ADVICE**

Problem	Possible Cause	Remedy
Difficulties in starting engine in cooling state.	Not enough fuel in fuel tank	Add fuel
	Spark plug is wet	Remove spark plug and dry
	Spark plug is damaged	Replace spark plug
	Spark plug connector lose	Check and secure
	Spark plug gap incorrect	Set gap to 0.025" (0.635mm)
Difficulties in restarting after a sudden stop.	Not enough fuel in fuel tank	Add fuel
	Carburettor is blocked	Check and clean
	Fuel filter is blocked	Replace fuel filter
	High carbon deposits found on spark plug	Remove carbon deposits from spark plug, clean filter
Slow speed or weak power.	Air filter is blocked	Replace air filter
	Fuel tank feed pipe or air vent blocked	Check and clean
	High carbon deposits found in combustion chamber	Remove carbon deposits
Abnormal sound	Damage or abrasion to active components	Replace worn parts
	High carbon deposits found in combustion chamber	Remove carbon deposits
Post Driver works but not efficiently	Rubber impact piston ring is aged or worn	Replace worn parts
Excessive smoke	Wrong fuel mixture	Drain fuel and replace

Spare Parts

A full range of spares are available. Please contact your Portek Dealer to request replacement parts.

Exploded drawings

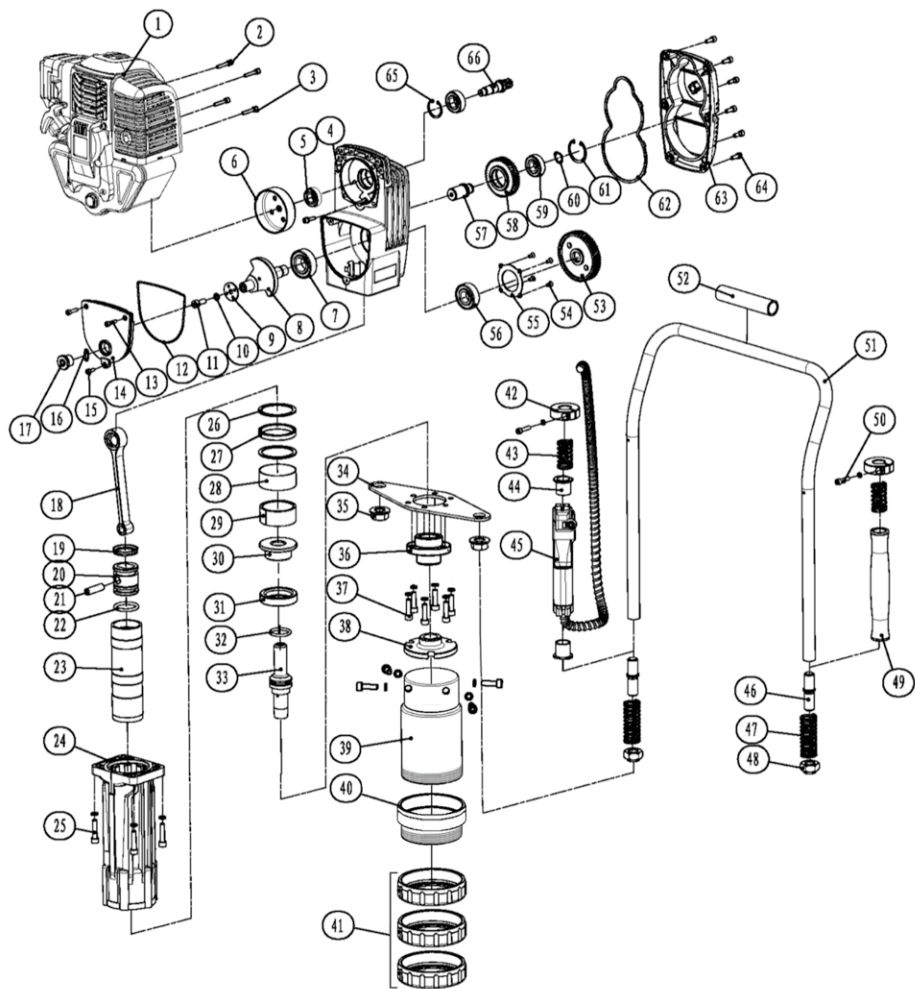

No.	Description	Qty	No.	Description	Qty
1	95A Gasoline Engine	1	33	Shock	1
2	Inner Hexagon		34	Support Plate	1
	Cheese-head Screw M6×25	3	35	Hexagon Flange Nut M18×1.5	2
3	Inner Hexagon		36	Shock Guide Sleeve	1
	Cheese-head Screw M6×20	2	37	Inner Hexagon	
4	Gearbox	1		Cheese-head Screw M8×40	6
5	Deep Groove Ball Bearings 6202-2RZ	1	38	Inner Pile Head	1
	Driven Disk	1	39	Standard Piling Socket	1
6	Deep Groove Ball Bearings 6205-2RZ	1	40	Reducing Adaptor	1
7	Impact Crankshaft	1	41	Plastic Sizing Ring	3
	Crankshaft Retainer	1	42	Positioning Sleeve	2
8	Elastic Washer 8×2.1	15	43	Compression Spring 22.5×27.5×60	2
9	Inner Hexagon		44	Switch Handle Guide Sleeve	2
	Cheese-head Screw M8×20	5	45	Combination Switch	1
10	Oil Storage Box Seal	1	46	Connecting Thread Head	2
11	Inner Hexagon		47	Compression Spring 22.5×27.5×123	2
	Cheese-head Screw M5×20	2	48	Step Nut	2
12	Oil Storage Box Lid	1	49	Handle Sleeve	1
13	Inner Hexagon		50	Inner Hexagon	
	Cheese-head Screw M5×16	1		Cheese-head Screw M6×40	2
14	O-ring 18×2.65	1	51	Steel tube handle	1
15	Oil Plug M20×1.5	1	52	Handle hose	1
16	Impact Connecting Rod	1	53	Big Gear	1
17	Lip-shaped Ring 35.5×45.5×6	1	54	Cross Recessed Countersunk Head Screw M5×10	4
18	Impact Piston	1	55	Bearing Holder	1
19	Impact Piston Pin	1	56	Deep Groove Ball Bearings 6204-2RZ	1
20	O-ring 35.5×5	1	57	Gear Shaft	1
21	Impact Cylinder	1	58	Middle Gear	1
22	Aluminium Hammer Case	1	59	Deep Groove Ball Bearings 6203-2RZ	2
23	Inner Hexagon		60	Shaft Retainer 17	1
	Cheese-head Screw M8×35	4	61	Hole Retainer 40	1
24	Iron Ring	2	62	Gearbox Cover Seal	1
25	Small Vibration Absorption Ring	1	63	Gearbox Cover	1
26	Opening Ring Rubber Circle	1	64	Inner Hexagon	
27	Opening Ring	1		Cheese-head Screw M6×16	6
28	Iron Handle Sleeve	1	65	Hole Retainer 35	1
29	Big Vibration Absorption Ring	1	66	Small Gear	1
30	O-ring 33×4	1			

Exploded drawings

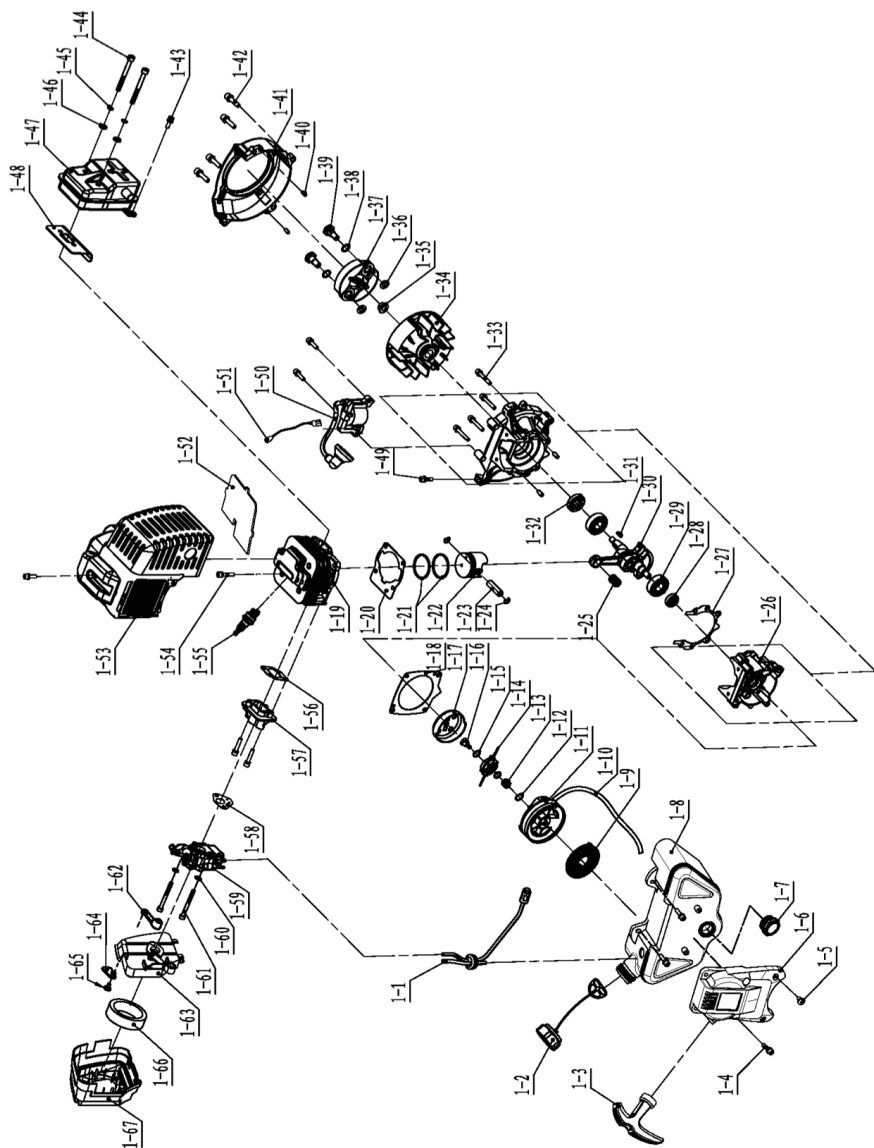

No.	Description	Qty	No.	Description	Qty
1-1	Oiler rubber assembly	1	1-36	Small washer 8.5×15×1.6	2
1-2	Fuel Tank Lid		1-37	Clutch inner	1
	Assembly Screw M5×20	1	1-38	Wave washer 10.5×15×0.5	2
1-3	Start Handle	1	1-39	Shaft Screw M8×10	2
1-4	Inner six angle cylinder head combined screw M5×20	4	1-40	Positioning Pin 5×10	2
1-5	Cross recessed countersunk head tapping screws ST4.8×13	2	1-41	Wind Scooper	1
1-6	starter	1	1-42	Inner six angle cylinder head combined screw M6×25	4
1-7	Oil Mirror	1	1-43	Inner six angle cylinder head combined screw M5×14	1
1-8	Fuel Tank	1	1-44	Internal six angle cylinder head screws M6×55	2
1-9	Start Disc Spring	1	1-45	Elastic washer 6×1.6	2
1-10	Rope	1	1-46	Plain washer C level 6×1.6	2
1-11	Start Rope Wheel	1	1-47	Silencer	1
1-12	Washer 10×14×0.5	1	1-48	Silencer Paper Pad	1
1-13	Start Spring	1	1-49	Inner six angle cylinder head combined screw M5×16	2
1-14	Start Paw Assembly	1	1-50	Igniter Assembly	1
1-15	Washer 9.5×12.5×0.8	2	1-51	Stop Wire	1
1-16	Start jaw screw	1	1-52	Cover Plate	1
1-17	Start Dial Disc	1	1-53	Cover	1
1-18	Starter Gasket	1	1-54	Inner six angle cylinder head combined screw M5×25	10
1-19	Cylinder	1	1-55	Spark Plug	1
1-20	Cylinder Gasket	1	1-56	Inlet Pipe Gasket	1
1-21	Piston Ring	2	1-57	Inlet Pipe	1
1-22	Piston	1	1-58	Carburettor Gasket	1
1-23	Piston Pin	1	1-59	Carburettor	1
1-24	Clamp Spring	2	1-60	Plain washer C level 5×12×1	2
1-25	Needle Roller Bearing HK101316	1	1-61	Internal six angle cylinder head screws M5×50	2
1-26	Left and right crankcase	1	1-62	Throttle switch	1
1-27	Case Sealing Paper Pad	1	1-63	Air Filter Seat	1
1-28	Oil Seal 12×22×7	1	1-64	Door stopper	1
1-29	Bearing 6202	2	1-65	Countersunk head screws C ST4×8	1
1-30	Crankshaft Assembly	1	1-66	Filter Screen	1
1-31	Woodruff Key 3×5×13	1	1-67	Air Filter Cover	1
1-32	Oil Seal 15×30×7	1			
1-33	Inner six angle cylinder head combined screw M5×35	4			
1-34	Magnetic Flywheels	1			
1-35	Hexagon flange nuts	1			

Declaration of Conformity

EC Declaration of Conformity

Portek Ltd, Bryn Hall, Knolton Bryn, Overton on Dee, Wrexham, LL13 0LF
declare that the machinery named below conforms to the requirements of
EC Council Machinery Directive, Annex II

Designation of Machinery: Portek Post Driver

Relevant EC Council Directives:
2006/42/EC (Machinery Directive)
2014/30/EU (Electromagnetic Compatibility Directive)

Applied Harmonised Standards:
BS EN ISO 12100:2010
BS EN 60745-1:2009+A11:2010
BS EN 55012:2007+A1:2009

Signature of Manufacturer's Representative:



Declaration made by Steve Morris
Design Engineer on 02/07/2018.



Portek Ltd.
Bryn Hall, Knolton Bryn
Overton-on-Dee
Wrexham, LL13 0LF
Tel: 01234 889 454
Fax: 01234 889 464

General enquiries
Email: info@portek.co.uk